

EC21 Mini PCIe

Hardware Design

LTE Module Series

Rev. EC21_Mini_PCl_e_Hardware_Design_V1.1

Date: 2017-01-24



Our aim is to provide customers with timely and comprehensive service. For any assistance, please contact our company headquarters:

Quectel Wireless Solutions Co., Ltd.

Office 501, Building 13, No.99, Tianzhou Road, Shanghai, China, 200233

Tel: +86 21 5108 6236

Email: info@quectel.com

Or our local office. For more information, please visit:

<http://www.quectel.com/support/salesupport.aspx>

For technical support, or to report documentation errors, please visit:

<http://www.quectel.com/support/techsupport.aspx>

Or email to: Support@quectel.com

GENERAL NOTES

QUECTEL OFFERS THE INFORMATION AS A SERVICE TO ITS CUSTOMERS. THE INFORMATION PROVIDED IS BASED UPON CUSTOMERS' REQUIREMENTS. QUECTEL MAKES EVERY EFFORT TO ENSURE THE QUALITY OF THE INFORMATION IT MAKES AVAILABLE. QUECTEL DOES NOT MAKE ANY WARRANTY AS TO THE INFORMATION CONTAINED HEREIN, AND DOES NOT ACCEPT ANY LIABILITY FOR ANY INJURY, LOSS OR DAMAGE OF ANY KIND INCURRED BY USE OF OR RELIANCE UPON THE INFORMATION. THE INFORMATION SUPPLIED HEREIN IS SUBJECT TO CHANGE WITHOUT PRIOR NOTICE.

COPYRIGHT

THE INFORMATION CONTAINED HERE IS PROPRIETARY TECHNICAL INFORMATION OF QUECTEL CO., LTD. TRANSMITTING, REPRODUCTION, DISSEMINATION AND EDITING OF THIS DOCUMENT AS WELL AS UTILIZATION OF THE CONTENT ARE FORBIDDEN WITHOUT PERMISSION. OFFENDERS WILL BE HELD LIABLE FOR PAYMENT OF DAMAGES. ALL RIGHTS ARE RESERVED IN THE EVENT OF A PATENT GRANT OR REGISTRATION OF A UTILITY MODEL OR DESIGN.

Copyright © Quectel Wireless Solutions Co., Ltd. 2017. All rights reserved.

About the Document

History

Revision	Date	Author	Description
1.0	2016-06-07	Yeoman CHEN/ Frank WANG	Initial
1.1	2017-01-24	Lyndon LIU/ Rex WANG	<ol style="list-style-type: none"> 1. Deleted description of EC21-AUTL and EC21-CT Mini PCIe in Table 1. 2. Updated key features of EC21 Mini PCIe in Table 2. 3. Added current consumption of EC21 Mini PCIe in Chapter 4.7. 4. Updated mechanical dimensions of EC21 Mini PCIe in Figure 15. 5. Updated conducted RF output power in Table 16. 6. Updated conducted RF receiving sensitivity of EC21-A in Table 18. 7. Added conducted RF receiving sensitivity of EC21-KL in Table 21. 8. Added conducted RF receiving sensitivity of EC21-J in Table 22.

Contents

About the Document	2
Contents	3
Table Index	5
Figure Index	6
1 Introduction	7
1.1. Safety Information.....	8
2 Product Concept	9
2.1. General Description.....	9
2.2. Description of Product Series.....	10
2.3. Key Features.....	11
2.4. Functional Diagram.....	13
3 Application Interface	14
3.1. General Description.....	14
3.2. EC21 Mini PCIe Interface.....	14
3.2.1. Definition of Interface.....	14
3.2.2. Pin Assignment.....	17
3.3. Power Supply.....	18
3.4. USIM Card Interface.....	19
3.5. USB Interface.....	20
3.6. UART Interface.....	21
3.7. PCM and I2C Interfaces.....	22
3.8. Control Signals.....	24
3.8.1. RI Signal.....	25
3.8.2. DTR Signal.....	25
3.8.3. W_DISABLE# Signal.....	25
3.8.4. PERST# Signal.....	25
3.8.5. LED_WWAN# Signal.....	26
3.8.6. WAKE# Signal.....	27
3.9. Antenna Interfaces.....	27
4 Electrical and Radio Characteristics	29
4.1. General Description.....	29
4.2. Power Supply Requirements.....	29
4.3. I/O Requirements.....	30
4.4. RF Characteristics.....	30
4.5. GNSS Receiver.....	33
4.6. ESD Characteristics.....	33
4.7. Current Consumption.....	34
5 Dimensions and Packaging	37
5.1. General Description.....	37

5.2.	Mechanical Dimensions of EC21 Mini PCIe.....	37
5.3.	Standard Dimensions of Mini PCI Express	38
5.4.	Packaging Specification.....	39
6	Appendix References	40

Quectel
Confidential

Table Index

TABLE 1: DESCRIPTION OF EC21 MINI PCIE.....	10
TABLE 2: KEY FEATURES OF EC21 MINI PCIE	11
TABLE 3: DEFINITION OF I/O PARAMETERS.....	14
TABLE 4: DESCRIPTION OF PINS	15
TABLE 5: DEFINITION OF VCC_3V3 AND GND PINS	18
TABLE 6: USIM PIN DEFINITION	19
TABLE 7: PIN DEFINITION OF USB INTERFACE	20
TABLE 8: PIN DEFINITION OF THE UART INTERFACE	21
TABLE 9: PIN DEFINITION OF PCM AND I2C INTERFACES	22
TABLE 10: PIN DEFINITION OF CONTROL SIGNAL	24
TABLE 11: RADIO OPERATIONAL STATES.....	25
TABLE 12: INDICATIONS OF NETWORK STATUS	26
TABLE 13: ANTENNA REQUIREMENTS.....	27
TABLE 14: POWER SUPPLY REQUIREMENTS.....	29
TABLE 15: I/O REQUIREMENTS.....	30
TABLE 16: EC21 MINI PCIE CONDUCTED RF OUTPUT POWER.....	30
TABLE 17: EC21-E MINI PCIE CONDUCTED RF RECEIVING SENSITIVITY	31
TABLE 18: EC21-A MINI PCIE CONDUCTED RF RECEIVING SENSITIVITY	31
TABLE 19: EC21-V MINI PCIE CONDUCTED RF RECEIVING SENSITIVITY	32
TABLE 20: EC21-AUT MINI PCIE CONDUCTED RF RECEIVING SENSITIVITY	32
TABLE 21: EC21-KL MINI PCIE CONDUCTED RF RECEIVING SENSITIVITY	32
TABLE 22: EC21-J MINI PCIE CONDUCTED RF RECEIVING SENSITIVITY	33
TABLE 23: ESD CHARACTERISTICS OF EC21 MINI PCIE	33
TABLE 24: CURRENT CONSUMPTION OF EC21-A MINI PCIE	34
TABLE 25: CURRENT CONSUMPTION OF EC21-V MINI PCIE	35
TABLE 26: CURRENT CONSUMPTION OF EC21-KL MINI PCIE	35
TABLE 27: GNSS CURRENT CONSUMPTION OF EC21 MINI PCIE SERIES MODULE.....	36
TABLE 28: RELATED DOCUMENTS	40
TABLE 29: TERMS AND ABBREVIATIONS	40

Figure Index

FIGURE 1: FUNCTIONAL DIAGRAM	13
FIGURE 2: PIN ASSIGNMENT	17
FIGURE 3: REFERENCE DESIGN OF POWER SUPPLY	18
FIGURE 4: REFERENCE CIRCUIT OF USIM CARD INTERFACE WITH A 6-PIN USIM CARD CONNECTOR	19
FIGURE 5: REFERENCE CIRCUIT OF USB INTERFACE	20
FIGURE 6: TIMING IN PRIMARY MODE	23
FIGURE 7: TIMING IN AUXILIARY MODE	23
FIGURE 8: REFERENCE CIRCUIT OF PCM APPLICATION WITH AUDIO CODEC	24
FIGURE 9: RI BEHAVIOR	25
FIGURE 10: TIMING OF RESETTING MODULE	26
FIGURE 11: LED_WWAN# SIGNAL REFERENCE CIRCUIT DIAGRAM	26
FIGURE 12: WAKE# BEHAVIOR	27
FIGURE 13: DIMENSIONS OF THE RF CONNECTOR (UNIT: MM)	28
FIGURE 14: MECHANICALS OF U.F.L-LP CONNECTORS	28
FIGURE 15: MECHANICAL DIMENSIONS OF EC21 MINI PCIE (UNIT: MM)	37
FIGURE 16: STANDARD DIMENSIONS OF MINI PCI EXPRESS (UNIT: MM)	38
FIGURE 17: DIMENSIONS OF THE MINI PCI EXPRESS CONNECTOR (THE MOLEX 679100002, UNIT: MM)	39

1 Introduction

This document defines EC21 Mini PCIe module and describes its hardware interfaces which are connected with your application and air interfaces.

This document can help you to quickly understand the interface specifications, electrical and mechanical details and related product information of the EC21 Mini PCIe module. To facilitate its application in different fields, relevant reference design documents are also provided. Associated with application note and user guide of EC21 Mini PCIe module, you can use the module to design and set up mobile applications easily.

Quectel
Confidential

1.1. Safety Information

The following safety precautions must be observed during all phases of the operation, such as usage, service or repair of any cellular terminal or mobile incorporating EC21 Mini PCIe module. Manufacturers of the cellular terminal should send the following safety information to users and operating personnel, and incorporate these guidelines into all manuals supplied with the product. If not so, Quectel does not take on any liability for customer failure to comply with these precautions.



Full attention must be given to driving at all times in order to reduce the risk of an accident. Using a mobile while driving (even with a handsfree kit) causes distraction and can lead to an accident. You must comply with laws and regulations restricting the use of wireless devices while driving.



Switch off the cellular terminal or mobile before boarding an aircraft. Make sure it is switched off. The operation of wireless appliances in an aircraft is forbidden, so as to prevent interference with communication systems. Consult the airline staff about the use of wireless devices on boarding the aircraft, if your device offers an Airplane Mode which must be enabled prior to boarding an aircraft.



Switch off your wireless device when in hospitals, clinics or other health care facilities. These requests are designed to prevent possible interference with sensitive medical equipment.



Cellular terminals or mobiles operating over radio frequency signal and cellular network cannot be guaranteed to connect in all conditions, for example no mobile fee or with an invalid USIM/SIM card. While you are in this condition and need emergent help, please remember using emergency call. In order to make or receive a call, the cellular terminal or mobile must be switched on and in a service area with adequate cellular signal strength.



Your cellular terminal or mobile contains a transmitter and receiver. When it is ON, it receives and transmits radio frequency energy. RF interference can occur if it is used close to TV set, radio, computer or other electric equipment.



In locations with potentially explosive atmospheres, obey all posted signs to turn off wireless devices such as your phone or other cellular terminals. Areas with potentially explosive atmospheres include fuelling areas, below decks on boats, fuel or chemical transfer or storage facilities, areas where the air contains chemicals or particles such as grain, dust or metal powders, etc.

2 Product Concept

2.1. General Description

EC21 Mini PCIe module provides data connectivity on LTE-FDD, LTE-TDD, WCDMA and GSM networks with PCI Express Mini Card 1.2 standard interface. It supports embedded operating systems such as WinCE, Linux and Android etc., and also provides audio, high-speed data transmission and GNSS functionality for your applications.

EC21 Mini PCIe module can be applied in the following fields:

- PDAs and Laptop Computer
- Remote Monitor System
- Vehicle System
- Wireless POS System
- Intelligent Meter Reading System
- Wireless Router and Switch
- Other Wireless Terminal Devices

This chapter generally introduces the following aspects of EC21 Mini PCIe module:

- Product Series
- Key Features
- Functional Diagram

NOTE

EC21 Mini PCIe contains **Telematics** version and **Data-only** version. **Telematics** version supports voice and data functions, while **Data-only** version only supports data function.

2.2. Description of Product Series

The following table shows the product series of EC21 Mini PCIe module.

Table 1: Description of EC21 Mini PCIe

Product Series	Description
EC21-E Mini PCIe	Support GSM: 900/1800MHz Support WCDMA: B1/B5/B8 Support LTE-FDD: B1/B3/B5/B7/B8/B20 Support LTE/WCDMA receive diversity Support GNSS ¹⁾ Support digital audio ²⁾
EC21-A Mini PCIe	Support WCDMA: B2/B4/B5 Support LTE-FDD: B2/B4/B12 Support LTE/WCDMA receive diversity Support GNSS ¹⁾ Support digital audio ²⁾
EC21-V Mini PCIe	Support LTE-FDD: B4/B13 Support LTE receive diversity Support GNSS ¹⁾ Support digital audio ²⁾
EC21-AUT Mini PCIe	Support WCDMA: B1/B5 Support LTE-FDD: B1/B3/B5/B7/B28 Support LTE/WCDMA receive diversity Support GNSS ¹⁾ Support digital audio ²⁾
EC21-AU Mini PCIe ³⁾	Support GSM: 850/900/1800/1900MHz Support WCDMA: B1/B2/B5/B8 Support LTE-FDD: B1/B2/B3/B4/B5/B7/B8/B28 Support LTE-TDD: B40 Support LTE/WCDMA receive diversity ³⁾ Support GNSS ¹⁾ Support digital audio ²⁾
EC21-J Mini PCIe	Support LTE-FDD: B1/B3/B8/B18/B19/B26 Support LTE receive diversity Support digital audio ²⁾
EC21-KL Mini PCIe	Support LTE-FDD: B1/B3/B5/B7/B8 Support LTE receive diversity Support digital audio ²⁾

NOTES

1. ¹⁾ GNSS function is optional.
2. ²⁾ Digital audio (PCM) function is only supported in **Telematics** version.
3. ³⁾ B2 band on EC21-AU Mini PCIe module does not support receive diversity.

2.3. Key Features

The following table describes the detailed features of EC21 Mini PCIe module.

Table 2: Key Features of EC21 Mini PCIe

Feature	Details
Function Interface	PCI Express Mini Card 1.2 Standard Interface
Power Supply	Supply voltage: 3.0~3.6V Typical supply voltage: 3.3V
Transmitting Power	Class 4 (33dBm±2dB) for GSM850 Class 4 (33dBm±2dB) for GSM900 Class 1 (30dBm±2dB) for DCS1800 Class 1 (30dBm±2dB) for PCS1800 Class E2 (27dBm±3dB) for GSM850 8-PSK Class E2 (27dBm±3dB) for GSM900 8-PSK Class E2 (26dBm±3dB) for DCS1800 8-PSK Class E2 (26dBm±3dB) for PCS1900 8-PSK Class 3 (24dBm+1/-3dB) for WCDMA bands Class 3 (23dBm±2dB) for LTE-FDD bands Class 3 (23dBm±2dB) for LTE-TDD bands
LTE Features	Support up to non-CA Cat 1 Support 1.4 to 20MHz RF bandwidth Support MIMO in DL direction FDD: Max 5Mbps (UL), 10Mbps (DL) TDD: Max 3.1Mbps (UL), 8.96Mbps (DL) TDD: Max 3.1Mbps (UL), 8.96Mbps (DL)
WCDMA Features	Support 3GPP R8 DC-HSPA+ Support 16-QAM, 64-QAM and QPSK modulation 3GPP R6 Cat 6 HSUPA: Max 5.76Mbps (UL) 3GPP R8 Cat 24 DC-HSPA+: Max 42Mbps (DL)
GSM Features	R99: CSD: 9.6kbps, 14.4kbps GPRS:

	<p>Support GPRS multi-slot class 12 (12 by default) Coding scheme: CS-1, CS-2, CS-3 and CS-4 Maximum of four Rx time slots per frame</p> <p>EDGE: Support EDGE multi-slot class 12 (12 by default) Support GMSK and 8-PSK for different MCS (Modulation and Coding Scheme) Downlink coding schemes: CS 1-4 and MCS 1-9 Uplink coding schemes: CS 1-4 and MCS 1-9</p>
Internet Protocol Features	<p>Support TCP/UDP/PPP/FTP/HTTP/NTP/PING/QMI/HTTPS*/SMTP*/MMS*/FTPS*/SSL* protocols</p> <p>Support PAP (Password Authentication Protocol) and CHAP (Challenge Handshake Authentication Protocol) protocols usually used for PPP connections</p>
SMS	<p>Text and PDU mode Point to point MO and MT SMS cell broadcast SMS storage: ME by default</p>
USIM Interface	Support USIM/SIM card: 1.8V, 3.0V
UART Interface	<p>Baud rate can reach up to 230400bps; 115200bps by default Used for AT command communication</p>
Audio Feature	<p>Support one digital audio interface: PCM interface GSM: HR/FR/EFR/AMR/AMR-WB WCDMA: AMR/AMR-WB LTE: AMR/AMR-WB Support echo cancellation and noise suppression</p>
PCM Interface	<p>Support 8-bit A-law*, μ-law* and 16-bit linear data formats Support long frame synchronization and short frame synchronization Support master and slave mode, but must be the master in long frame synchronization</p>
USB Interface	<p>Compliant with USB 2.0 specification (slave only), the data transfer rate can reach up to 480Mbps Used for AT command communication, data transmission, firmware upgrade, software debugging, GNSS NMEA output and voice over USB* USB Driver: Windows XP, Windows Vista, Windows 7, Windows 8/8.1, Windows 10, Linux 2.6 or later, Android 4.0/4.2/4.4/5.0/5.1/6.0</p>
Antenna Interface	Include main antenna, diversity antenna and GNSS antenna
Rx-diversity	Support LTE/WCDMA Rx-diversity
GNSS Features	<p>Gen 8C Lite of Qualcomm Protocol: NMEA 0183</p>
AT Commands	Compliant with 3GPP TS 27.007, 27.005 and Quectel enhanced AT commands

Physical Characteristics	Size: (51.0±0.1) × (30.0±0.1) × (4.9±0.2) mm Weight: approx. 9.8g
Temperature Range	Operation temperature range: -35°C ~ +75°C ²⁾ Extended temperature range: -40°C ~ +80°C ³⁾
Firmware Upgrade	USB interface and DFOTA*
RoHS	All hardware components are fully compliant with EU RoHS directive

NOTES

1. "*" means under development.
2. ²⁾ Within operating temperature range, the module is 3GPP compliant.
3. ³⁾ Within extended temperature range, the module remains the ability to establish and maintain a voice, SMS, data transmission, emergency call, etc. There is no unrecoverable malfunction; there are also no effects on radio spectrum and no harm to radio network. Only one or more parameters like P_{out} might reduce in their value and exceed the specified tolerances. When the temperature returns to normal operating temperature levels, the module is compliant with 3GPP specification again.

2.4. Functional Diagram

The following figure shows the block diagram of EC21 Mini PCIe.

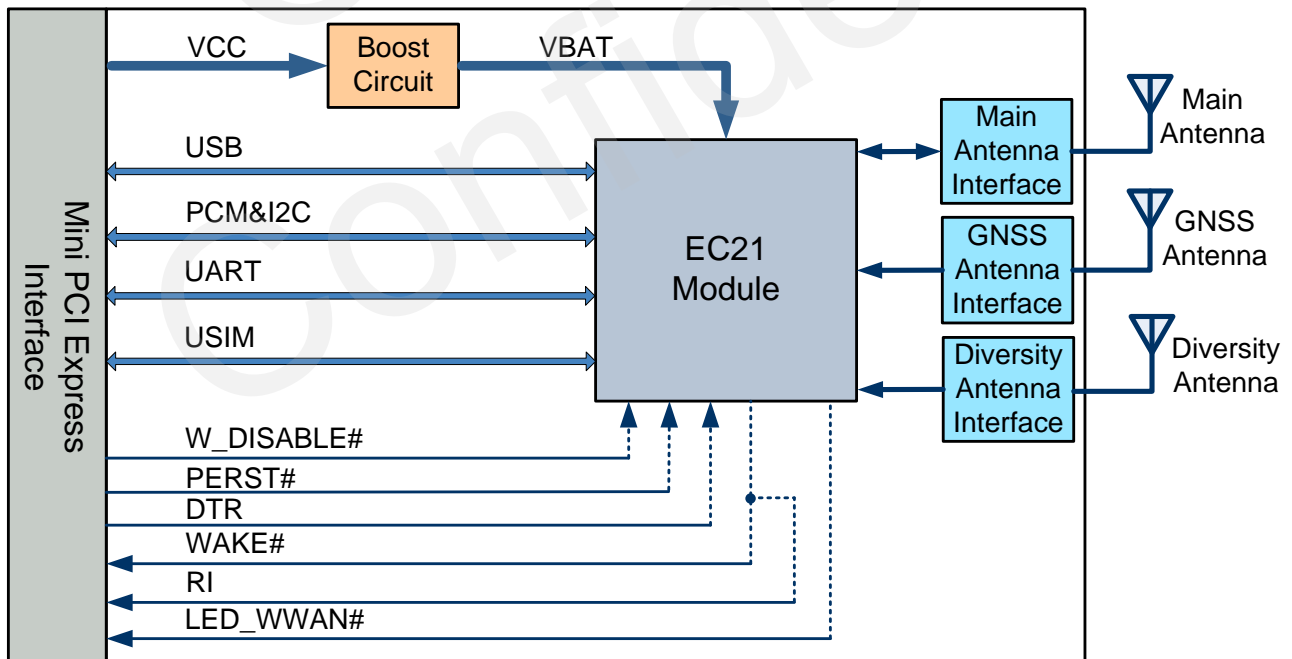

Figure 1: Functional Diagram

3 Application Interface

3.1. General Description

The physical connections and signal levels of EC21 Mini PCIe comply with PCI Express Mini CEM specifications. This chapter mainly describes the following interface definition and application of EC21 Mini PCIe:

- Power supply
- USIM card interface
- USB interface
- UART interface
- PCM&I2C interfaces
- Control signals
- Antenna interface

3.2. EC21 Mini PCIe Interface

3.2.1. Definition of Interface

The following tables show the pin definition and description of EC21 Mini PCIe on the 52-pin application.

Table 3: Definition of I/O Parameters

Type	Description
IO	Bidirectional
DI	Digital input
DO	Digital output
OC	Open collector
PI	Power input
PO	Power output

Table 4: Description of Pins

Pin No.	Mini PCI Express Standard Name	EC21 Mini PCIe Pin Name	I/O	Description	Comment
1	WAKE#	WAKE#	OC	Output signal can be used to wake up the host.	
2	3.3Vaux	VCC_3V3	PI	3.3V DC supply	
3	COEX1	RESERVED		Reserved	
4	GND	GND		Mini card ground	
5	COEX2	RESERVED		Reserved	
6	1.5V	NC			
7	CLKREQ#	RESERVED		Reserved	
8	UIM_PWR	USIM_VDD	PO	Power source for the USIM card	
9	GND	GND		Mini card ground	
10	UIM_DATA	USIM_DATA	IO	USIM data signal	
11	REFCLK-	UART_RX	DI	UART receive data	Connect to DTE's TX
12	UIM_CLK	USIM_CLK	DO	USIM clock signal	
13	REFCLK+	UART_TX	DO	UART transmit data	Connect to DTE's RX
14	UIM_RESET	USIM_RST	DO	USIM reset signal	
15	GND	GND		Mini card ground	
16	UIM_VPP	RESERVED		Reserved	
17	RESERVED	RI	DO	Output signal can be used to wake up the host.	
18	GND	GND		Mini card ground	
19	RESERVED	RESERVED		Reserved	
20	W_DISABLE#	W_DISABLE#	DI	Disable wireless communications	Pull-up Active low
21	GND	GND		Mini card ground	
22	PERST#	PERST#	DI	Functional reset to the card	Active low
23	PERn0	UART_CTS	DI	UART clear to send	Connect to DTE's RTS
24	3.3Vaux	RESERVED		Reserved	

25	PERp0	UART_RTS	DO	UART request to send	Connect to DTE's CTS
26	GND	GND		Mini card ground	
27	GND	GND		Mini card ground	
28	1.5V	NC			
29	GND	GND		Mini card ground	
30	SMB_CLK	I2C_SCL	DO	I2C serial clock	Require external pull-up to 1.8V.
31	PETn0	DTR	DI	Sleep mode control	
32	SMB_DATA	I2C_SDA	IO	I2C serial data	Require external pull-up to 1.8V.
33	PETp0	RESERVED		Reserved	
34	GND	GND		Mini card ground	
35	GND	GND		Mini card ground	
36	USB_D-	USB_DM	IO	USB differential data (-)	
37	GND	GND		Mini card ground	
38	USB_D+	USB_DP	IO	USB differential data (+)	
39	3.3Vaux	VCC_3V3	PI	3.3V DC supply	
40	GND	GND		Mini card ground	
41	3.3Vaux	VCC_3V3	PI	3.3V DC supply	
42	LED_WWAN#	LED_WWAN#	OC	Active-low. LED signal for indicating the state of the card.	
43	GND	GND		Mini card ground	
44	LED_WLAN#	RESERVED		Reserved	
45	RESERVED	PCM_CLK*	IO	PCM clock signal	
46	LED_WPAN#	RESERVED		Reserved	
47	RESERVED	PCM_DOUT*	DO	PCM data output	
48	1.5V	NC			

49	RESERVED	PCM_DIN*	DI	PCM data input
50	GND	GND		Mini card ground
51	RESERVED	PCM_SYNC*	IO	PCM frame synchronization
52	3.3Vaux	VCC_3V3	PI	3.3V DC supply

NOTES

1. The typical supply voltage is 3.3V.
2. Keep all NC, reserved and unused pins unconnected.
3. “*” means the digital audio (PCM) function is only supported on **Telematics** version.

3.2.2. Pin Assignment

The following figure shows the pin assignment of EC21 Mini PCIe module. The top side contains EC21 module and antenna connectors.

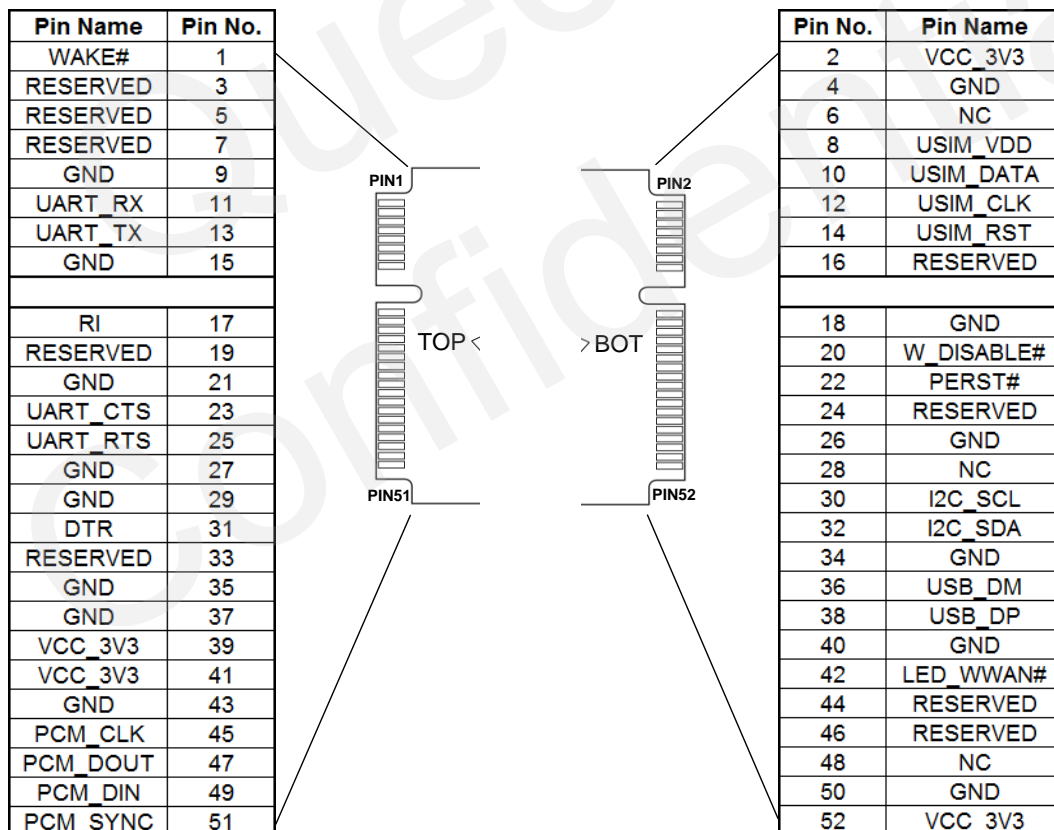

Figure 2: Pin Assignment

3.3. Power Supply

The following table shows pin definition of VCC_3V3 pins and ground pins.

Table 5: Definition of VCC_3V3 and GND Pins

Pin No.	Pin Name	I/O	Power Domain	Description
2, 39, 41, 52	VCC_3V3	PI	3.0~3.6V	3.3V DC supply
4, 9, 15, 18, 21, 26, 27, 29, 34, 35, 37, 40, 43, 50	GND			Mini card ground

The typical supply voltage of EC21 Mini PCIe is 3.3V. In the 2G networks, the input peak current may reach to 2.7A during the transmitting time, therefore the power supply must be able to provide enough current, and a bypass capacitor of no less than 470μF with low ESR should be used to prevent the voltage from dropping.

The following figure shows a reference design of power supply. The precision of resistor R2 and R3 is 1%, and the capacitor C3 needs a low ESR.

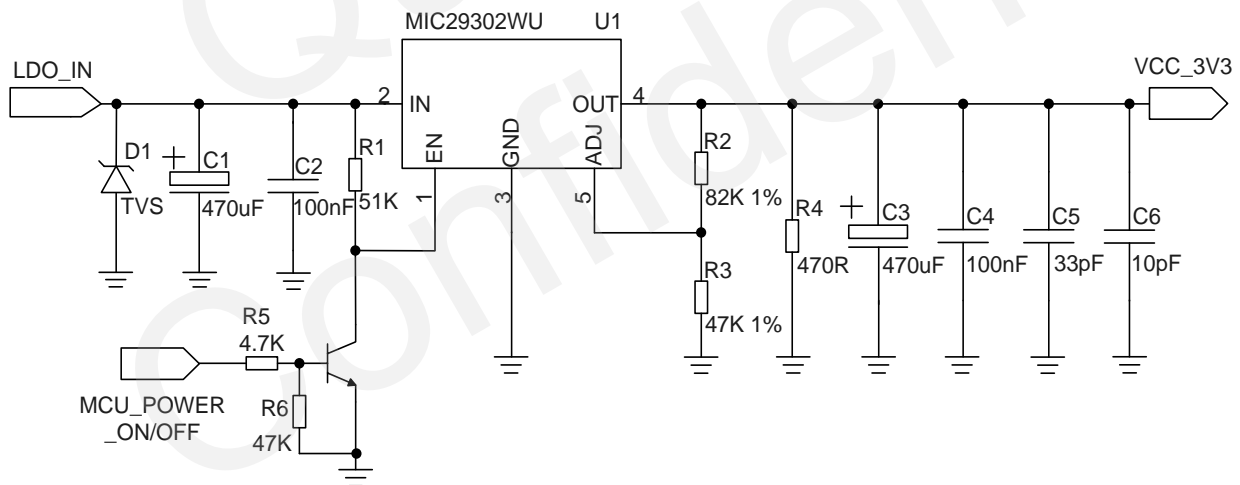

Figure 3: Reference Design of Power Supply

3.4. USIM Card Interface

The following table shows the pin definition of USIM card interface.

Table 6: USIM Pin Definition

Pin No.	Pin Name	I/O	Power Domain	Description
8	USIM_VDD	PO	1.8V/3.0V	Power source for the USIM card
10	USIM_DATA	IO	1.8V/3.0V	USIM data signal
12	USIM_CLK	DO	1.8V/3.0V	USIM clock signal
14	USIM_RST	DO	1.8V/3.0V	USIM reset signal

EC21 Mini PCIe supports 1.8V and 3.0V USIM cards. The following figure shows the reference design of the 6-pin USIM card connector.

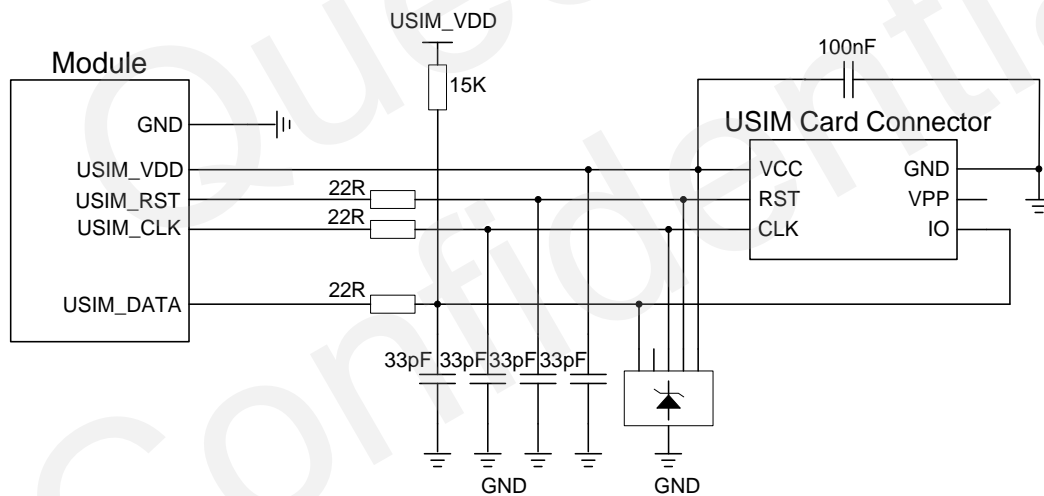

Figure 4: Reference Circuit of USIM Card Interface with a 6-Pin USIM Card Connector

In order to enhance the reliability and availability of the USIM card in your application, please follow the criteria below in USIM circuit design:

- Keep layout of USIM card as close to the module as possible. Assure the trace length as less than 200mm as possible.
- Keep USIM card signal away from RF and power supply traces.
- Keep the trace width of ground and USIM_VDD no less than 0.5mm to maintain the same electric potential. The decouple capacitor of USIM_VDD should be less than 1uF and must near to USIM card connector.

- To avoid cross-talk between USIM_DATA and USIM_CLK, keep them away from each other and shield them with surrounding ground.
- In order to offer good ESD protection, it is recommended to add a TVS whose parasitic capacitance should not be more than 50pF. The 22 ohm resistors should be added in series between the module and USIM card so as to suppress EMI spurious transmission and enhance ESD protection. The 33pF capacitors are used for filtering interference of GSM900. Please note that the USIM peripheral circuit should be close to the USIM card connector.
- The pull-up resistor on USIM_DATA line can improve anti-jamming capability when long layout trace and sensitive occasion are applied, and should be placed close to the USIM card connector.

3.5. USB Interface

The following table shows the pin definition of USB interface.

Table 7: Pin Definition of USB Interface

Pin No.	Pin Name	I/O	Description	Comment
36	USB_DM	IO	USB differential data (-)	Require differential impedance of 90Ω
38	USB_DP	IO	USB differential data (+)	Require differential impedance of 90Ω

EC21 Mini PCIe is compliant with USB 2.0 specification. It can only be used as a slave device. Meanwhile, it supports high speed (480Mbps) and full speed (12Mbps) mode. The USB interface is used for AT command communication, data transmission, GNSS NMEA output, software debugging, firmware upgrade and voice over USB*. The following figure shows the reference circuit of USB interface.

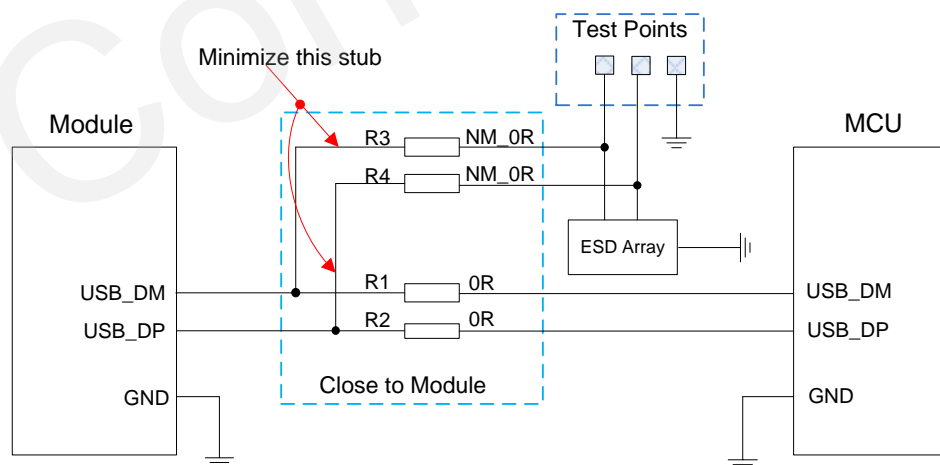

Figure 5: Reference Circuit of USB Interface

In order to ensure the integrity of USB data line signal, components R1, R2, R3 and R4 must be placed close to the module, and also these resistors should be placed close to each other. The extra stubs of trace must be as short as possible.

In order to ensure the USB interface design corresponding with the USB 2.0 specification, please comply with the following principles:

- It is important to route the USB signal traces as differential pairs with total grounding. The impedance of USB differential trace is 90 ohm.
- Do not route signal traces under crystals, oscillators, magnetic devices and RF signal traces. It is important to route the USB differential traces in inner-layer with ground shielding on not only upper and lower layers but also right and left sides.
- If USB connector is used, please keep the ESD protection components to the USB connector as close as possible. Pay attention to the influence of junction capacitance of ESD protection components on USB data lines. Typically, the capacitance value should be less than 2pF.
- Keep the ESD components as close as possible to the connector.
- Keep traces of USB data test points short to avoid noise coupled on USB data lines. If possible, reserve a 0R resistor on these two lines.

NOTES

1. There are three preconditions when enabling EC21 Mini PCIe to enter into the sleep mode:
 - a) Execute **AT+QSCLK=1** command to enable the sleep mode. Please refer to **document [2]** for details.
 - b) DTR pin should be kept in high level (pull-up internally).
 - c) USB interface on Mini PCIe must be connected with the USB interface of the host and please guarantee the USB of the host is in suspended state.
2. "*" means under development.

3.6. UART Interface

The following table shows the pin definition of the UART interface.

Table 8: Pin Definition of the UART Interface

Pin No.	EC21 Mini PCIe Pin Name	I/O	Power Domain	Description
11	UART_RX	DI	3.3V	UART receive data
13	UART_TX	DO	3.3V	UART transmit data

23	UART_CTS	DI	3.3V	UART clear to send
25	UART_RTS	DO	3.3V	UART request to send

The UART interface supports 9600, 19200, 38400, 57600, 115200 and 230400bps baud rate. The default is 115200bps. This interface can be used for AT command communication.

NOTE

AT+IPR command can be used to set the baud rate of the UART, and **AT+IFC** command can be used to set the hardware flow control (hardware flow control is disabled by default). Please refer to **document [2]** for details.

3.7. PCM and I2C Interfaces

The following table shows the pin definition of PCM and I2C interfaces that can be applied in audio codec design.

Table 9: Pin Definition of PCM and I2C Interfaces

Pin No.	Pin Name	I/O	Power Domain	Description
45	PCM_CLK	IO	1.8V	PCM clock signal
47	PCM_DOUT	DO	1.8V	PCM data output
49	PCM_DIN	DI	1.8V	PCM data input
51	PCM_SYNC	IO	1.8V	PCM frame synchronization
30	I2C_SCL	DO	1.8V	I2C serial clock, require external pull-up to 1.8V.
32	I2C_SDA	IO	1.8V	I2C serial data, require external pull-up to 1.8V.

EC21 Mini PCIe provides one PCM digital interface, which supports 8-bit A-law* and μ -law*, and also supports 16-bit linear data formats and the following modes:

- Primary mode (short frame synchronization, works as either master or slave)
- Auxiliary mode (long frame synchronization, works as master only)

NOTE

“*” means under development.

In primary mode, the data is sampled on the falling edge of the PCM_CLK and transmitted on the rising edge. The PCM_SYNC falling edge represents the MSB. In this mode, PCM_CLK supports 128kHz, 256kHz, 512kHz, 1024kHz and 2048kHz. The following figure shows timing relationship in primary mode with 8kHz PCM_SYNC and 2048kHz PCM_CLK.

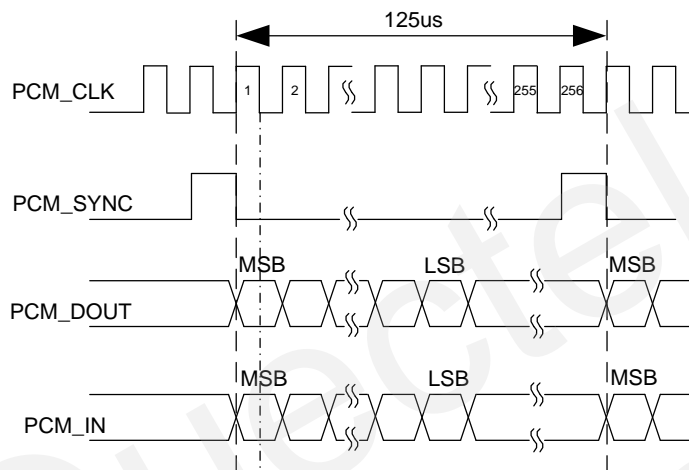

Figure 6: Timing in Primary Mode

In auxiliary mode, the data is sampled on the falling edge of the PCM_CLK and transmitted on the rising edge; while the PCM_SYNC rising edge represents the MSB. In this mode, PCM interface operates with a 128kHz PCM_CLK and an 8kHz, 50% duty cycle PCM_SYNC only. The following figure shows the timing relationship in auxiliary mode with 8kHz PCM_SYNC and 128kHz PCM_CLK.

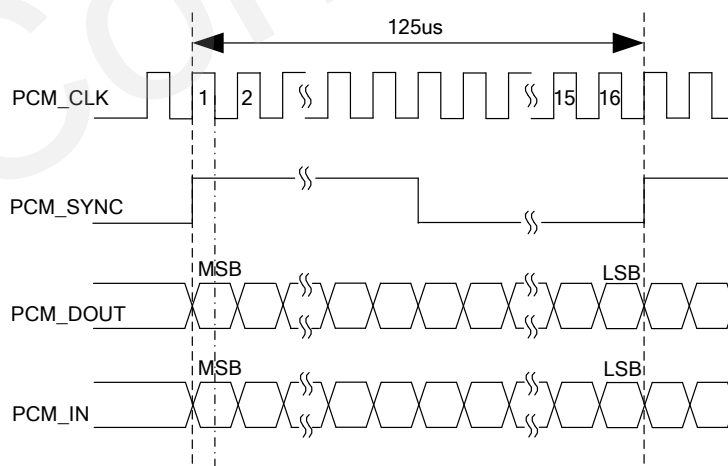

Figure 7: Timing in Auxiliary Mode

Clock and mode can be configured by AT command, and the default configuration is master mode using short frame synchronization data format with 2048kHz PCM_CLK and 8kHz PCM_SYNC. In addition, EC21 Mini PCIe's firmware has integrated the configuration on some PCM codec's application with I2C interface. Please refer to **document [2]** for details about **AT+QDAI** command.

The following figure shows a reference design of PCM interface with external codec IC.

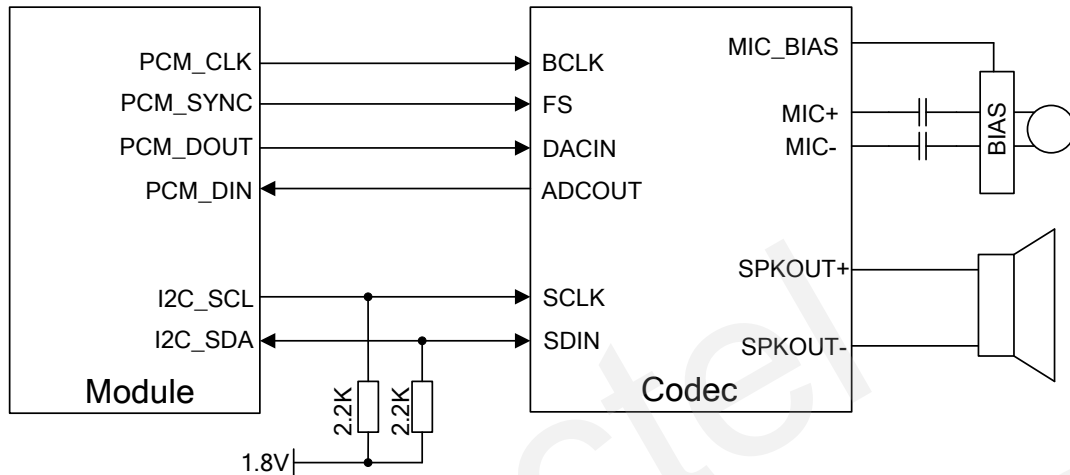

Figure 8: Reference Circuit of PCM Application with Audio Codec

3.8. Control Signals

The following table shows the pin definition of control signals.

Table 10: Pin Definition of Control Signal

Pin No.	Pin Name	I/O	Power Domain	Description
17	RI	DO	3.3V	Output signal can be used to wake up the host.
31	DTR	DI	3.3V	Sleep mode control.
20	W_DISABLE#	DI	3.3V	Disable wireless communications, pull-up by default, active low.
22	PERST#	DI	3.3V	Functional reset to the card, active low.
42	LED_WWAN#	OC		Active-low. LED signal for indicating the state of the module.
1	WAKE#	OC		Output signal can be used to wake up the host.

3.8.1. RI Signal

The RI signal can be used to wake up the host. When URC returns, there will be the following behavior on the RI pin after executing **AT+QCFG="risignalttype","physical"** command.

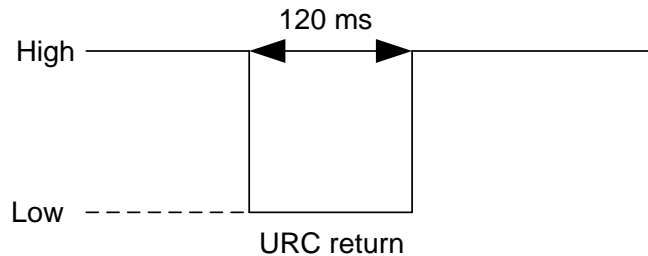

Figure 9: RI Behavior

3.8.2. DTR Signal

The DTR signal supports sleep control function. Driving it to low level will wake up the module.

3.8.3. W_DISABLE# Signal

EC21 Mini PCIe provides W_DISABLE# signal to disable wireless communications through hardware operation. The following table shows the radio operational states of the module. Please refer to **document [2]** for related AT commands.

Table 11: Radio Operational States

W_DISABLE#	AT Commands	Radio Operation
High Level	AT+CFUN=1	Enabled
High Level	AT+CFUN=0 AT+CFUN=4	Disabled
Low Level	AT+CFUN=0 AT+CFUN=1 AT+CFUN=4	Disabled

3.8.4. PERST# Signal

The PERST# signal can be used to force a hardware reset on the card. You can reset the module by driving the PERST# to a low level voltage within the time frame of 150~460ms and then releasing it. The reset scenario is illustrated in the following figure.

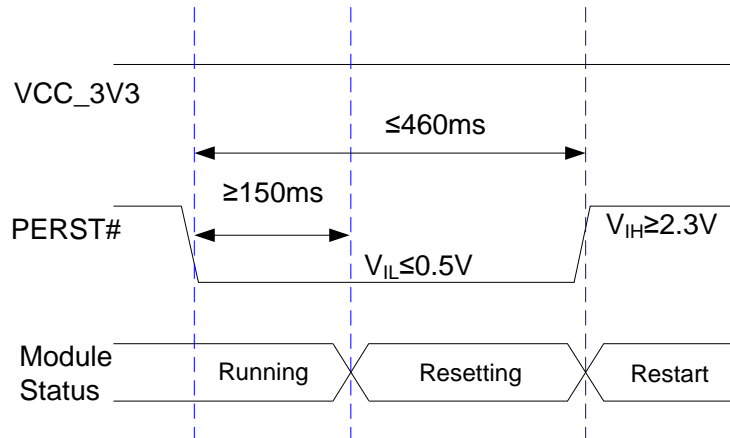

Figure 10: Timing of Resetting Module

3.8.5. LED_WWAN# Signal

The LED_WWAN# signal of EC21 Mini PCIe is used to indicate the network status of the module, which can absorb the current up to 40mA. According to the following circuit, in order to reduce the current of the LED, a resistor must be placed in series with the LED. The LED is emitting light when the LED_WWAN# output signal is active low.

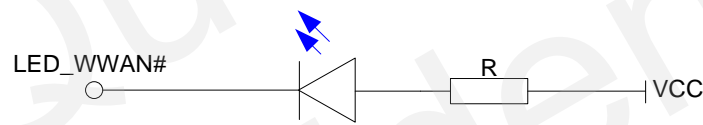

Figure 11: LED_WWAN# Signal Reference Circuit Diagram

The following table shows the network status indications of the LED_WWAN# signal.

Table 12: Indications of Network Status

LED_WWAN#	Description
Low Level (Light on)	Registered on network
High-impedance (Light off)	<ul style="list-style-type: none"> ● No network coverage or not registered ● W_DISABLE# signal is at low level. (Disable the RF) ● AT+CFUN=0, AT+CFUN=4

3.8.6. WAKE# Signal

The WAKE# signal is an open collector signal which is similar to RI signal, but a host pull-up resistor and **AT+QCFG="risignaltype","physical"** command are required. When URC returns, there will be 120ms low level pulse output as below.

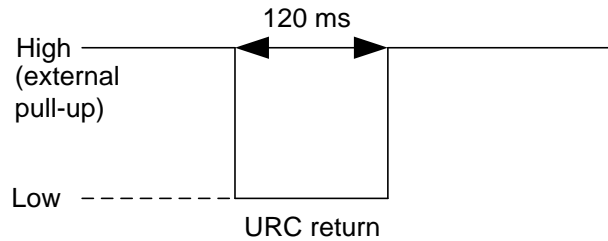

Figure 12: WAKE# Behavior

3.9. Antenna Interfaces

EC21 Mini PCIe antenna interfaces include a main antenna interface, a Rx-diversity antenna interface and a GNSS antenna interface. And Rx-diversity function is enabled by default.

The following table shows the requirement on main antenna, Rx-diversity antenna and GNSS antenna.

Table 13: Antenna Requirements

Type	Requirements
GNSS	Frequency range: 1561~1615MHz Polarization: RHCP or linear VSWR: <2 (Typ.) Passive antenna gain: >0dBi
GSM/WCDMA/LTE	VSWR: ≤2 Gain (dBi): 1 Max Input Power (W): 50 Input Impedance (ohm): 50 Polarization Type: Vertical Cable Insertion Loss: <1dB (GSM900, WCDMA B5/B8, LTE B5/B8/B12/B13/B20/B28) Cable Insertion Loss: <1.5dB (GSM1800, WCDMA B1/B2, LTE B1/B2/B3/B4) Cable insertion loss <2dB (LTE B7)

The following figure shows the overall sizes of RF connector.

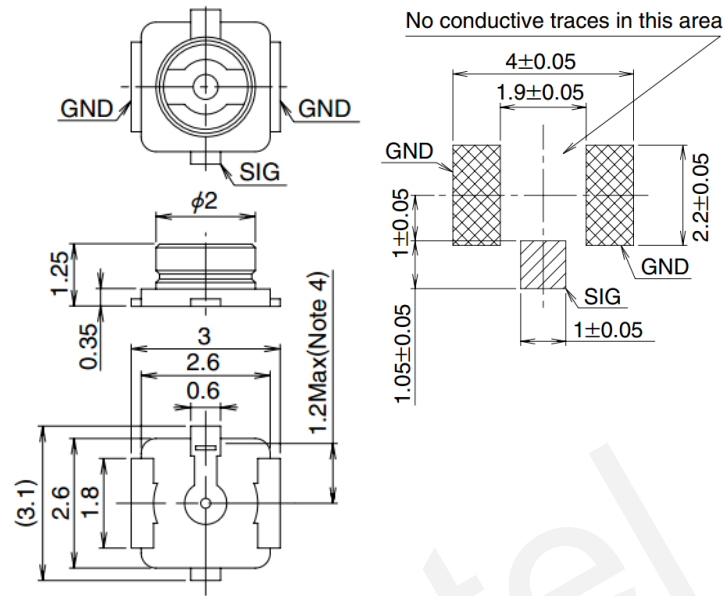

Figure 13: Dimensions of the RF Connector (Unit: mm)

U.FL-LP serial connectors listed in the following figure can be used to match the RF connector.

	U.FL-LP-040	U.FL-LP-066	U.FL-LP(V)-040	U.FL-LP-062	U.FL-LP-088
Part No.					
Mated Height	2.5mm Max. (2.4mm Nom.)	2.5mm Max. (2.4mm Nom.)	2.0mm Max. (1.9mm Nom.)	2.4mm Max. (2.3mm Nom.)	2.4mm Max. (2.3mm Nom.)
Applicable cable	Dia. 0.81mm Coaxial cable	Dia. 1.13mm and Dia. 1.32mm Coaxial cable	Dia. 0.81mm Coaxial cable	Dia. 1mm Coaxial cable	Dia. 1.37mm Coaxial cable
Weight (mg)	53.7	59.1	34.8	45.5	71.7
RoHS	YES				

Figure 14: Mechanicals of UF.L-LP Connectors

4 Electrical and Radio Characteristics

4.1. General Description

This chapter mainly describes the following electrical and radio characteristics of EC21 Mini PCIe:

- Power supply requirements
- I/O requirements
- Current consumption
- RF characteristics
- GNSS receiver
- ESD characteristics

4.2. Power Supply Requirements

The input voltage of EC21 Mini PCIe is $3.3V \pm 9\%$, as specified by *PCI Express Mini CEM Specifications 1.2*. The following table shows the power supply requirements of EC21 Mini PCIe.

Table 14: Power Supply Requirements

Parameter	Description	Min.	Typ.	Max.	Unit
VCC_3V3	Power Supply	3.0	3.3	3.6	V

4.3. I/O Requirements

The following table shows the I/O requirements of EC21 Mini PCIe.

Table 15: I/O Requirements

Parameter	Description	Min.	Max.	Unit
V _{IH}	Input High Voltage	0.7 × VCC_3V3	VCC_3V3+0.3	V
V _{IL}	Input Low Voltage	-0.3	0.3 × VCC_3V3	V
V _{OH}	Output High Voltage	VCC_3V3-0.5	VCC_3V3	V
V _{OL}	Output Low Voltage	0	0.4	V

NOTES

1. The PCM and I2C interfaces belong to 1.8V power domain and other I/O interfaces belong to VCC_3V3 power domain.
2. The maximum voltage value of V_{IL} for PERST# signal and W_DISABLE# signal is 0.5V.

4.4. RF Characteristics

The following tables show conducted RF output power and receiving sensitivity of EC21 Mini PCIe module.

Table 16: EC21 Mini PCIe Conducted RF Output Power

Frequency	Max.	Min.
GSM850/GSM900	33dBm±2dB	5dBm±5dB
DCS1800/PCS1900	30dBm±2dB	0dBm±5dB
GSM850/GSM900 (8-PSK)	27dBm±3dB	5dBm±5dB
DCS1800/PCS1900 (8-PSK)	26dBm±3dB	0dBm±5dB
WCDMA bands	24dBm+1/-3dB	<-50dBm
LTE-FDD bands	23dBm±2dB	<-44dBm

LTE-TDD bands

23dBm±2dB

<-44dBm

Table 17: EC21-E Mini PCIe Conducted RF Receiving Sensitivity

Frequency	Primary	Diversity	SIMO	3GPP (SIMO)
GSM	-109.0dBm	/	/	-102.0dBm
DCS	-109.0dBm	/	/	-102.0dbm
WCDMA B1	-110.5dBm	/	/	-106.7dBm
WCDMA B5	-110.5dBm	/	/	-104.7dBm
WCDMA B8	-110.5dBm	/	/	-103.7dBm
LTE-FDD B1 (10M)	-98.0dBm	-98.0dBm	-101.5dBm	-96.3dBm
LTE-FDD B3 (10M)	-96.5dBm	-98.5dBm	-101.5dBm	-93.3dBm
LTE-FDD B5 (10M)	-98.0dBm	-98.5dBm	-101.0dBm	-94.3dBm
LTE-FDD B7 (10M)	-97.0dBm	-94.5dBm	-99.5dBm	-94.3dBm
LTE-FDD B8 (10M)	-97.0dBm	-97.0dBm	-101.0dBm	-93.3dBm
LTE-FDD B20 (10M)	-97.5dBm	-99.0dBm	-102.5dBm	-93.3dBm

Table 18: EC21-A Mini PCIe Conducted RF Receiving Sensitivity

frequency	Primary	Diversity	SIMO	3GPP (SIMO)
WCDMA B2	-110.0dBm	/	/	-104.7dBm
WCDMA B4	-110.0dBm	/	/	-106.7dBm
WCDMA B5	-110.5dBm	/	/	-104.7dBm
LTE-FDD B2 (10M)	-98.0dBm	-98.0dBm	-101.0dBm	-94.3dBm
LTE-FDD B4 (10M)	-97.5dBm	-99.0dBm	-101.0dBm	-96.3dBm
LTE-FDD B12 (10M)	-96.5dBm	-98.0dBm	-101.0dBm	-93.3dBm

Table 19: EC21-V Mini PCIe Conducted RF Receiving Sensitivity

Frequency	Primary	Diversity	SIMO	3GPP (SIMO)
LTE-FDD B4 (10M)	-97.5dBm	-99.0dBm	-101.0dBm	-96.3dBm
LTE-FDD B13 (10M)	-95.0dBm	-97.0dBm	-100.0dBm	-93.3dBm

Table 20: EC21-AUT Mini PCIe Conducted RF Receiving Sensitivity

Frequency	Primary	Diversity	SIMO	3GPP (SIMO)
WCDMA B1	-110.0dBm	/	/	-106.7dBm
WCDMA B5	-110.5dBm	/	/	-104.7dBm
LTE-FDD B1 (10M)	-98.5dBm	-98.0dBm	-101.0dBm	-96.3dBm
LTE-FDD B3 (10M)	-98.0dBm	-96.0dBm	-100.0dBm	-93.3dBm
LTE-FDD B5 (10M)	-98.0dBm	-99.0dBm	-102.5dBm	-94.3dBm
LTE-FDD B7 (10M)	-97.0dBm	-95.0dBm	-98.5dBm	-94.3dBm
LTE-FDD B28 (10M)	-97.0dBm	-99.0dBm	-102.0dBm	-94.8dBm

Table 21: EC21-KL Mini PCIe Conducted RF Receiving Sensitivity

Frequency	Primary	Diversity	SIMO	3GPP (SIMO)
LTE-FDD B1 (10M)	-98.0dBm	-99.5dBm	-100.5dBm	-96.3dBm
LTE-FDD B3 (10M)	-97.0dBm	-97.5dBm	-99.5dBm	-93.3dBm
LTE-FDD B5 (10M)	-98.0dBm	-99.5dBm	-100.5dBm	-94.3dBm
LTE-FDD B7 (10M)	-96.0dBm	-96.0dBm	-98.5dBm	-94.3dBm
LTE-FDD B8 (10M)	-97.0dBm	-99.0dBm	-101.0dBm	-93.3dBm

Table 22: EC21-J Mini PCIe Conducted RF Receiving Sensitivity

Frequency	Primary	Diversity	SIMO	3GPP (SIMO)
LTE-FDD B1 (10M)	-97.5dBm	-98.7dBm	-100.2dBm	-96.3dBm
LTE-FDD B3 (10M)	-96.5dBm	-97.1dBm	-100.5dBm	-93.3dBm
LTE-FDD B8 (10M)	-98.4dBm	-99.0dBm	-101.2dBm	-93.3dBm
LTE-FDD B18 (10M)	-99.5dBm	-99.0dBm	-101.7dBm	-96.3dBm
LTE-FDD B19 (10M)	-99.2dBm	-99.0dBm	-101.4dBm	-96.3dBm
LTE-FDD B26 (10M)	-99.5dBm	-99.0dBm	-101.5dBm	-93.8dBm

4.5. GNSS Receiver

EC21 Mini PCIe integrates a GNSS receiver that supports Gen8C Lite of Qualcomm (GPS, GLONASS, BeiDou, Galileo and QZSS). Meanwhile, it supports Qualcomm gpsOneXTRA technology (one kind of A-GNSS). This technology will download XTRA file from the internet server to enhance the TTFF. XTRA file contains predicted GPS and GLONASS satellites coordinates and clock biases valid for up to 7 days. It is best if XTRA file is downloaded every 1-2 days. Additionally, EC21 Mini PCIe can support standard NMEA-0183 protocol and output NMEA messages with 1Hz via USB NMEA interface.

EC21 Mini PCIe GNSS engine is switched off by default. You must switch on it by AT command. Please refer to **document [3]** for more details about GNSS engine technology and configurations. A passive antenna should be used for the GNSS engine.

4.6. ESD Characteristics

The following table shows the ESD characteristics of EC21 Mini PCIe.

Table 23: ESD Characteristics of EC21 Mini PCIe

Part	Contact Discharge	Air Discharge	Unit
Power Supply and GND	+/-5	+/-10	kV
Antenna Interface	+/-4	+/-8	kV

USB Interface	+/-4	+/-8	kV
USIM Interface	+/-4	+/-8	kV
Others	+/-0.5	+/-1	kV

4.7. Current Consumption

The following tables describe the current consumption of EC21 Mini PCIe series module.

Table 24: Current Consumption of EC21-A Mini PCIe

Parameter	Description	Conditions	Typ.	Unit
I _V BAT	Sleep state	AT+CFUN=0 (USB disconnected)	3.5	mA
		WCDMA PF=64 (USB disconnected)	5.0	mA
		WCDMA PF=128 (USB disconnected)	4.4	mA
		LTE-FDD PF=64 (USB disconnected)	5.3	mA
		LTE-FDD PF=128 (USB disconnected)	4.5	mA
	Idle state	WCDMA PF=64 (USB disconnected)	32.0	mA
		WCDMA PF=64 (USB connected)	45.0	mA
		LTE-FDD PF=64 (USB disconnected)	32.0	mA
	WCDMA data transfer (GNSS OFF)	LTE-FDD PF=64 (USB connected)	45.0	mA
		WCDMA B2 HSDPA @21.59dBm	582.0	mA
WCDMA B2 HSUPA @22.17dBm		675.0	mA	
WCDMA B4 HSDPA @21.47dBm		575.0	mA	
WCDMA B4 HSUPA @21.73dBm		637.0	mA	
WCDMA B5 HSDPA @20.02dBm		686.0	mA	
WCDMA B5 HSUPA @20.18dBm		577.0	mA	
LTE data transfer (GNSS OFF)	LTE-FDD B2 @22.93dBm	926.0	mA	
	LTE-FDD B4 @22.72dBm	934.0	mA	

	LTE-FDD B12 @23.26dBm	835.0	mA
WCDMA voice call	WCDMA B2 @22.88dBm	610.0	mA
	WCDMA B4 @23.21dBm	743.0	mA
	WCDMA B5 @23.13dBm	643.0	mA

Table 25: Current Consumption of EC21-V Mini PCIe

Parameter	Description	Conditions	Typ.	Unit
I _{VBAT}	Sleep state	AT+CFUN=0 (USB disconnected)	3.8	mA
		LTE-FDD PF=64 (USB disconnected)	5.3	mA
		LTE-FDD PF=128 (USB disconnected)	4.9	mA
	Idle state	LTE-FDD PF=64 (USB disconnected)	30.0	mA
		LTE-FDD PF=64 (USB connected)	42.0	mA
	LTE data transfer (GNSS OFF)	LTE-FDD B4 @23.59dBm	997.0	mA
	LTE-FDD B13 @24.05dBm	724.0	mA	

Table 26: Current Consumption of EC21-KL Mini PCIe

Parameter	Description	Conditions	Typ.	Unit
I _{VBAT}	Sleep state	AT+CFUN=0 (USB disconnected)	3.5	mA
		LTE-FDD PF=64 (USB disconnected)	5.6	mA
		LTE-FDD PF=128 (USB disconnected)	4.7	mA
	Idle state	LTE-FDD PF=64 (USB disconnected)	35.0	mA
		LTE-FDD PF=64 (USB connected)	49.0	mA
	LTE data transfer (GNSS OFF)	LTE-FDD B1 @22.78dBm	972.0	mA
	LTE-FDD B3 @23.03dBm	974.0	mA	
	LTE-FDD B5 @23.03dBm	764.0	mA	
	LTE-FDD B7 @22.89dBm	959.0	mA	

LTE-FDD B8 @22.86dBm 839.0 mA

Table 27: GNSS Current Consumption of EC21 Mini PCIe Series Module

Parameter	Description	Conditions	Typ.	Unit
I _{VBAT} (GNSS)	Searching (AT+CFUN=0)	Cold start @Passive Antenna	75.0	mA
		Lost state @Passive Antenna	74.0	mA
	Tracking (AT+CFUN=0)	Instrument environment	44.0	mA
		Open Sky @Passive Antenna	53.0	mA
		Open Sky @Active Antenna	58.0	mA

Quectel
Confidential

5 Dimensions and Packaging

5.1. General Description

This chapter mainly describes mechanical dimensions as well as packaging specification of EC21 Mini PCIe module.

5.2. Mechanical Dimensions of EC21 Mini PCIe

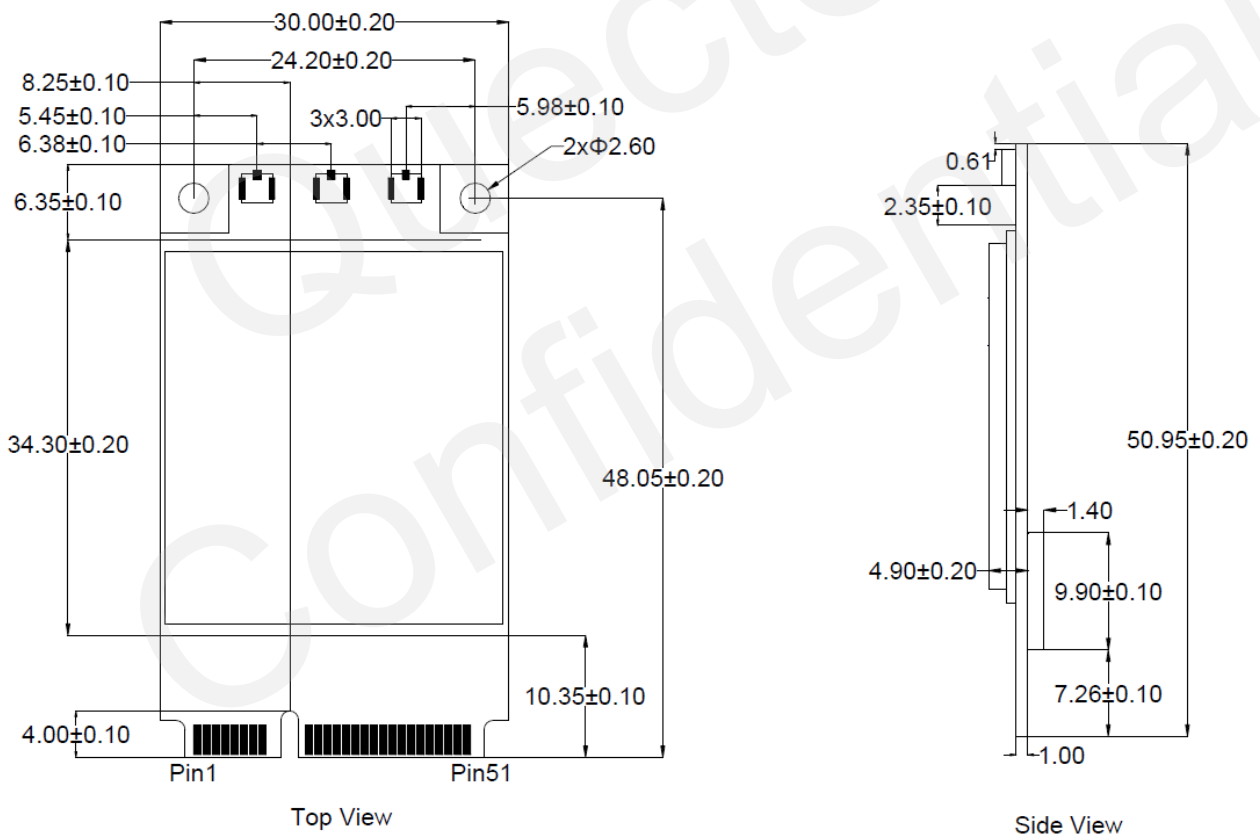

Figure 15: Mechanical Dimensions of EC21 Mini PCIe (Unit: mm)

5.3. Standard Dimensions of Mini PCI Express

The following figure shows the standard dimensions of Mini PCI Express. Please refer to **document [1]** for detailed A and B.

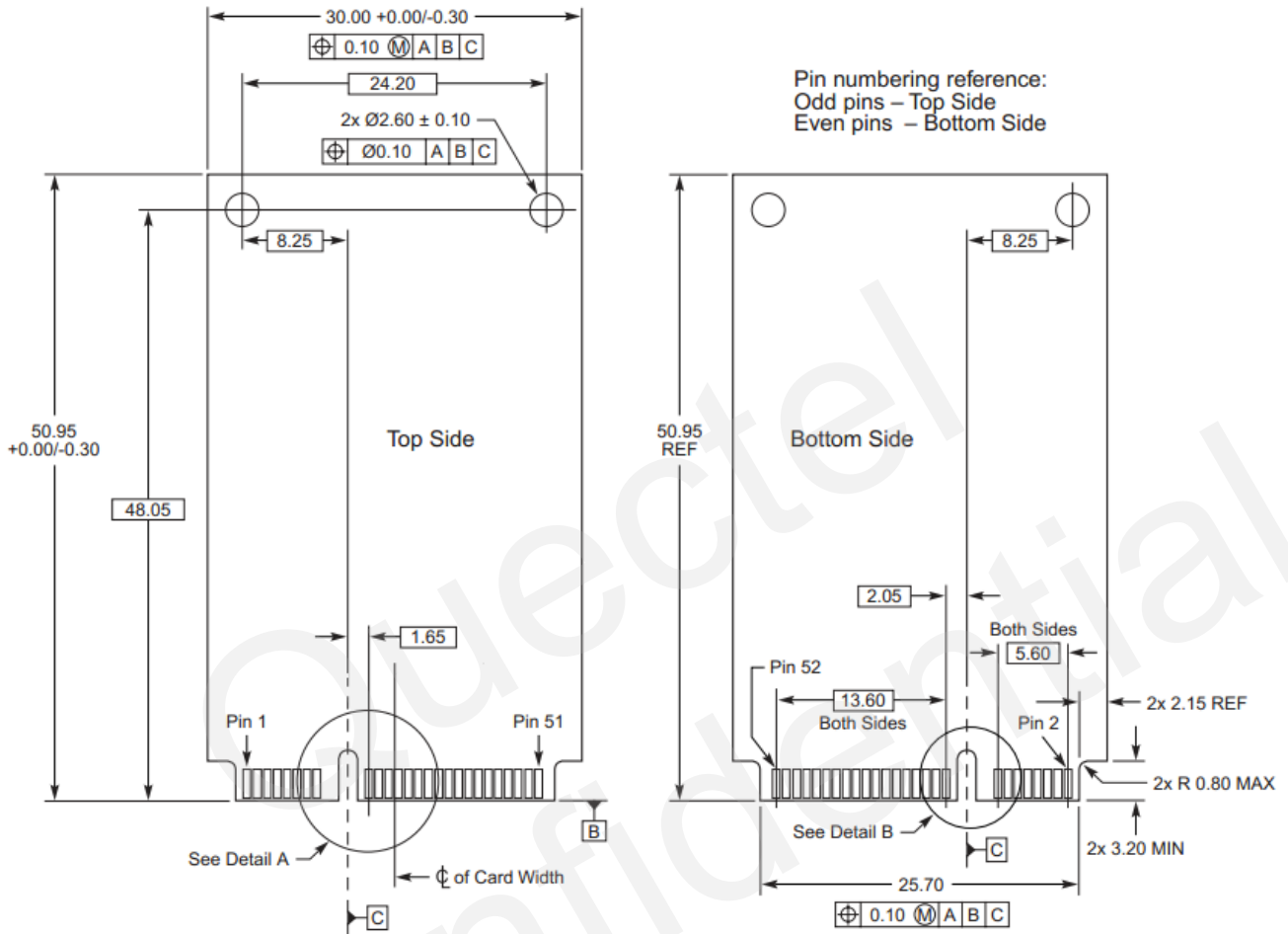

Figure 16: Standard Dimensions of Mini PCI Express (Unit: mm)

EC21 Mini PCIe adopts a standard Mini PCI Express connector which complies with the directives and standards listed in the **document [1]**. The following figure takes the Molex 679100002 as an example.

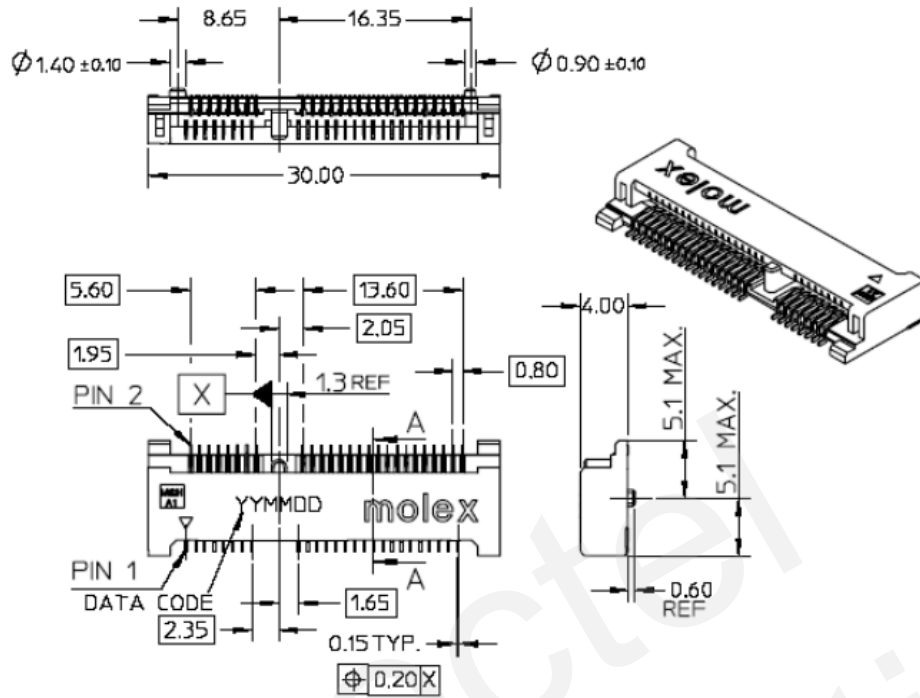

Figure 17: Dimensions of the Mini PCIe Connector (the Molex 679100002, Unit: mm)

5.4. Packaging Specification

The EC21 Mini PCIe is packaged in tray. Each tray contains 10pcs of modules. The smallest package of EC21 Mini PCIe contains 100pcs.

6 Appendix References

Table 28: Related Documents

SN	Document Name	Remark
[1]	PCI Express Mini Card Electromechanical Specification Revision 1.2	Mini PCI Express Specification
[2]	Quectel_EC25&EC21_AT_Commands_Manual	EC25 and EC21 AT Commands Manual
[3]	Quectel_EC25&EC21_GNSS_AT_Commands_Manual	EC25 and EC21 GNSS AT Commands Manual

Table 29: Terms and Abbreviations

Abbreviation	Description
AMR	Adaptive Multi-rate
bps	Bits Per Second
CS	Coding Scheme
DC-HSPA+	Dual-carrier High Speed Packet Access
DFOTA	Delta Firmware Upgrade Over The Air
DL	Down Link
EFR	Enhanced Full Rate
ESD	Electrostatic Discharge
FDD	Frequency Division Duplexing
FR	Full Rate
GLONASS	GLObalnaya Navigatsionnaya Sputnikovaya Sistema, the Russian Global Navigation Satellite System
GMSK	Gaussian Minimum Shift Keying
GNSS	Global Navigation Satellite System

GPS	Global Positioning System
GSM	Global System for Mobile Communications
HR	Half Rate
HSPA	High Speed Packet Access
HSUPA	High Speed Uplink Packet Access
kbps	Kilo Bits Per Second
LED	Light Emitting Diode
LTE	Long-Term Evolution
Mbps	Million Bits Per Second
ME	Mobile Equipment (Module)
MIMO	Multiple-Input Multiple-Output
MMS	Multimedia Messaging Service
MO	Mobile Originated
MT	Mobile Terminated
PCM	Pulse Code Modulation
PDU	Protocol Data Unit
PPP	Point-to-Point Protocol
RF	Radio Frequency
Rx	Receive
USIM	Universal Subscriber Identification Module
SMS	Short Message Service
UART	Universal Asynchronous Receiver & Transmitter
UL	Up Link
URC	Unsolicited Result Code
WCDMA	Wideband Code Division Multiple Access